

847 - Comfort Panel - IP65 - for aseptic environments

Code: 150256-00

GENERAL INFORMATION

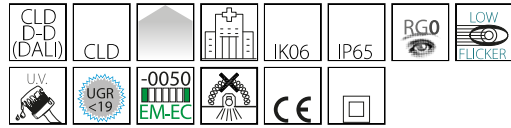

Article	847 - Comfort Panel - IP65 - for aseptic environments
Code	150256-00

DIMENSIONS AND WEIGHT

Length (mm)	595 mm
Width (mm)	595 mm
Height (mm)	35 mm
Weight (Kg)	2.6 kg

ELECTRICAL CHARACTERISTICS AND CONTROLS

Voltage type	AC
Min Voltage (V)	220 V
Max Voltage (V)	240 V
Min Frequency (Hz)	50 Hz
Max Frequency (Hz)	60 Hz
Frequency (Hz)	50 Hz
Wiring name	CLD
Power factor	≥0.95
Insulation class	Class II
Controllability	None

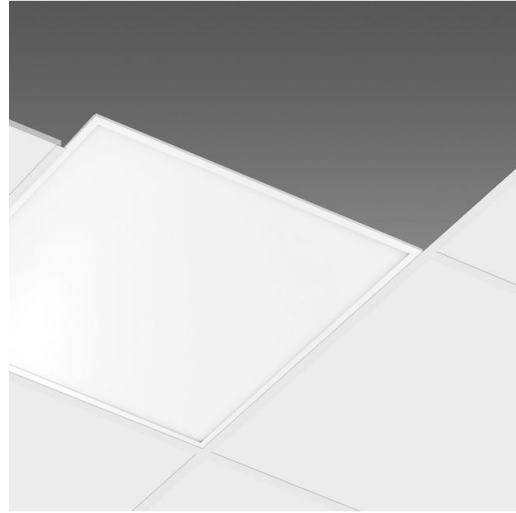

Disano presents a range of lighting fixtures designed to meet the special needs of clean rooms where the control of bacterial contamination is important. In response to the specific requirements of this sector, the installation of dedicated luminaires is fundamental. Aseptic hospital rooms, operation theatres, laboratories and corridors are all spaces where a high level of safety and a screened light for an improved visual comfort are required.



847 - Comfort Panel - IP65 - for aseptic environments

Code: 150256-00

PHOTOMETRIC DATA

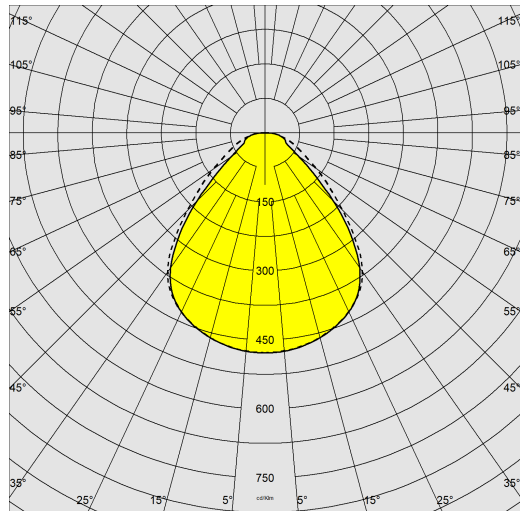

Lighting source	LED
CRI	>80
Luminous flux (output) (lm)	3360 lm
Power absorption (total) (W)	24 W
CCT	4000 K
Luminous efficacy (lm/W)	140 lm/W
Unified glare rating UGR (EN 12464-1) (Reflectance coefficient: ceiling 0.7 - walls 0.5)	UGR<19, according to standard EN 12464.
Low Flicker	luminaire with very low flicker: evenly distributed light for greater visual safety.
LED flux maintenance	80000 hr, L 90, B 10

MECHANICAL CHARACTERISTICS

Impact resistance rating (IK)	IK06
IP	65



847 - Comfort Panel - IP65 - for aseptic environments

Code: 150256-00

MATERIALS AND COLOURS

Housing	in pressed steel sheet.
Diffuser	in high transmittance opal technopolymer.
Coating	polyester powder coated, UV-stabilised, anti-yellowing, phosphate pre-treatment.
Colour	White
Equipment	Ceiling lighting fixture with external driver; it can be easily housed in false ceilings.

EMERGENCY LIGHTING

Emergency power supply type	Not present
-----------------------------	-------------

STANDARDS AND COMPLIANCE

Photobiological safety class	RG0
Markings and tests	CE
Reference standards	EN60598-1. They have a degree of protection according to the EN60529 standard.
Energy Label	C

WARRANTY

After sales warranty	5 yr
----------------------	------

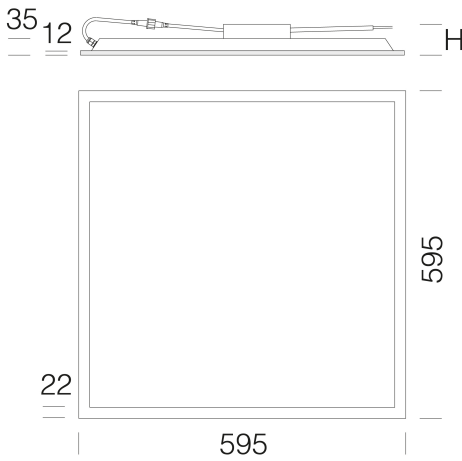

DOWNLOAD

DESIGNS

TechnicalDrawing 847-g.dxf



847 - Comfort Panel - IP65 - for aseptic environments

Code: 150256-00

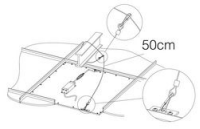

320 Cord

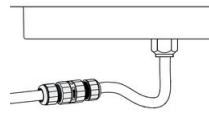

339 Connector