

2885 - Saturno ø370

Code: 330772-0041

GENERAL INFORMATION

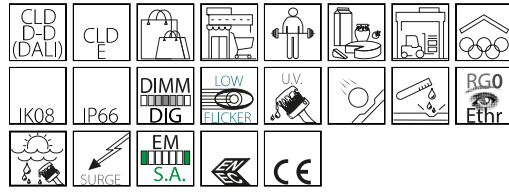

Article	2885 - Saturno ø370
Code	330772-0041

DIMENSIONS AND WEIGHT

Height (mm)	150 mm
Diameter (Ø) (mm)	370 mm
Weight (Kg)	4.4 kg

ELECTRICAL CHARACTERISTICS AND CONTROLS

Voltage type	AC
Min Voltage (V)	220 V
Max Voltage (V)	240 V
Min Frequency (Hz)	50 Hz
Max Frequency (Hz)	60 Hz
Frequency (Hz)	50 Hz
Wiring name	CLD-D-D
Control interface	DALI
Power factor	≥0.95
Surge protector (common) (EN 61547)	4 kV
Insulation class	Class I
Controllability	Yes (External control)



The Saturno industrial reflector with LED sources is a cutting-edge lighting solution, ideal for industrial facilities, shopping centres, and high-rise environments.

Equipped with narrow, elliptical, and wide beam optics, Saturno offers exceptional versatility in light distribution, delivering uniform and targeted illumination to meet diverse design needs. Its outstanding luminous efficiency ensures reduced energy consumption without compromising on brightness, maintaining intense and consistent illumination. Built to withstand the toughest environmental conditions, Saturno is renowned for its durability and robust design, guaranteeing long-term reliable performance.

Its clean, functional lines blend seamlessly into any setting, enhancing visibility and safety through superior lighting performance. With Saturno, you can achieve top-notch light quality that meets even the most demanding requirements, making it the ideal choice for those seeking efficiency, reliability, and exceptional performance.



2885 - Saturno ø370

Code: 330772-0041

PHOTOMETRIC DATA

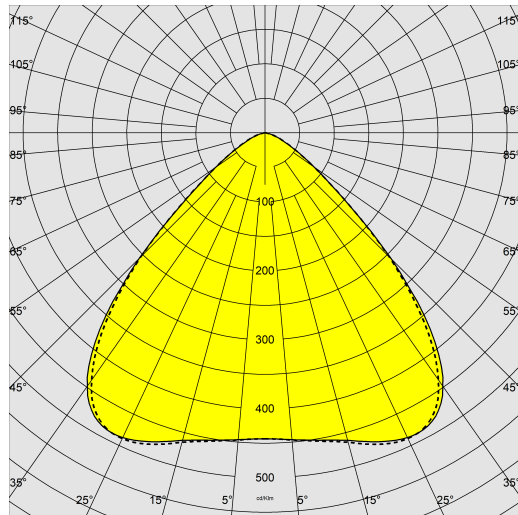

Lighting source	LED
CRI	80
Luminous flux (output) (lm)	19800 lm
Power absorption (total) (W)	100 W
CCT	4000 K
Low Flicker	luminaire with very low flicker: evenly distributed light for greater visual safety.
Colour consistency	SDCM3
LED flux maintenance	100000 hr, L 80, B 10

MECHANICAL CHARACTERISTICS

Impact resistance rating (IK)	IK08
IP	66
Ambient temperature - min	-40 °C
Ambient temperature - max	60 °C

2885 - Saturno ø370

Code: 330772-0041

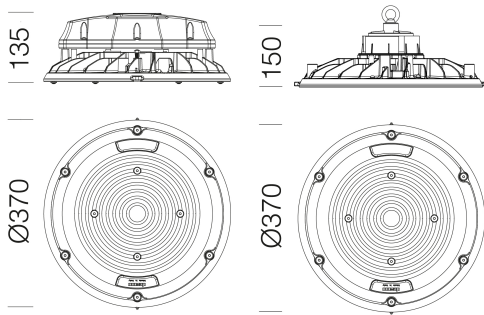

DOWNLOAD

MOUNTS

[AssemblyInstructions gonsaturno.pdf](#)

[AssemblyInstructions saturno dismart 01-21.pdf](#)

[AssemblyInstructions Saturno DALI-EM.pdf](#)

[AssemblyInstructions Saturno DALI.pdf](#)

[AssemblyInstructions saturno370 10-24 v2.pdf](#)

DESIGNS

[BIM 2885 370 - DALI-EM 06-25.zip](#)

[TechnicalDrawing 2885-370-em-dim.dxf](#)



MATERIALS AND COLOURS

Housing	in die-cast aluminium with cooling fins integrated in the cover.
Diffuser	transparent polycarbonate, LED with protective lenses.
Heat sink	the heat sink is designed and made to allow the LEDs to operate at temperatures capable of ensuring excellent performance/output and long service life.
Coating	the fully automated powder-coating cycle involves a polyester-based, salt-spray corrosion-resistant and UV-stabilised paint., Anthracite = RAL 7021
Special coating (UPON REQUEST)	Upon request: protective coating recommended for marine environments within 5 km (3 miles) of the sea.
Colour	Graphite
Equipment	<ul style="list-style-type: none"> - waterproof connector for quick installation with no need to open the fixture - temperature controller with auto-reset - EN 61547 compliant surge protection. - anti-condensation valve
Emergency wiring -07: acc.1175 (997651-00) to be purchased separately for 200W version.	

EMERGENCY LIGHTING

Emergency power supply type	Not present
-----------------------------	-------------

STANDARDS AND COMPLIANCE

Photobiological safety class	RG0
Markings and tests	CE, ENEC
Reference standards	EN60598-1. They have a degree of protection according to the EN60529 standard.
Energy Label	C

GEAR

Sensors	
Upon request	-Class II fixtures, protection up to 10KV.

WARRANTY

After sales warranty	5 yr
----------------------	------

2885 - Saturno ø370

Code: 330772-0041

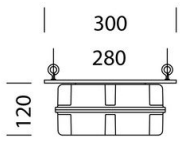

1175 EM Box - 997651-00 - S.A.

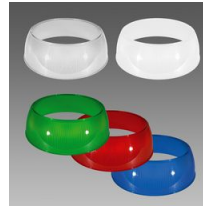

540 Skirt - 370 mm