

## 2885 - Saturno ø370 HE - high efficiency

Code: 330775-00

### GENERAL INFORMATION

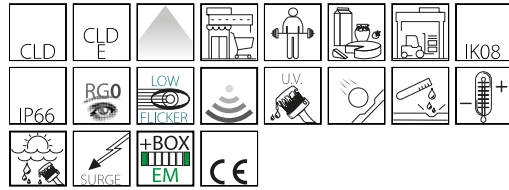

Article	2885 - Saturno ø370 HE - high efficiency
Code	330775-00

### DIMENSIONS AND WEIGHT

Height (mm)	135 mm
Diameter (Ø) (mm)	370 mm
Weight (Kg)	5 kg

### ELECTRICAL CHARACTERISTICS AND CONTROLS

Voltage type	AC
Min Voltage (V)	220 V
Max Voltage (V)	240 V
Min Frequency (Hz)	50 Hz
Max Frequency (Hz)	60 Hz
Frequency (Hz)	50 Hz
Wiring name	CLD
Power factor	≥0.95
Surge protector (common) (EN 61547)	4 kV, 6 kV
Insulation class	Class I
Controllability	None



Saturno LED by Disano Illuminazione: the lamp designed for environmentally and work friendly lighting.

- Disano's range of lighting fixtures for warehouses and manufacturing facilities is extended with new products.
- Saturno LED is the right alternative solution to achieve the best performance, without wasting energy, in spaces where maximum power is not needed.
- Built with the best materials and made to last in time, these fixtures are designed to ensure increased light control.

An increasingly energy-efficient manufacturing process is making sustainability the most important challenge for companies that aim at maximum competitiveness. The use of new lighting technologies in manufacturing facilities allows achieving three fundamental goals: to save energy while ensuring economic and environmental benefits, to improve safety and comfort in workplaces and to increase productivity. The new LED lighting fixtures cut energy consumption by half and offer superior light quality, in line with the market demands. Manufacturing facilities are changing, dedicating increasingly greater space to automation and precision processes. LED sources ensure high colour rendering, which results in better viewing and positive effects on the workers' health and wellbeing. Disano's range of spotlights was designed to allow the best use of new sources and technologies for a more efficient management of the lighting system in industrial settings. The possibility to choose the product with the most suitable technical features allows for the optimisation of the economic investment, reaching increasingly higher levels of performance.



## 2885 - Saturno ø370 HE - high efficiency

Code: 330775-00

### PHOTOMETRIC DATA

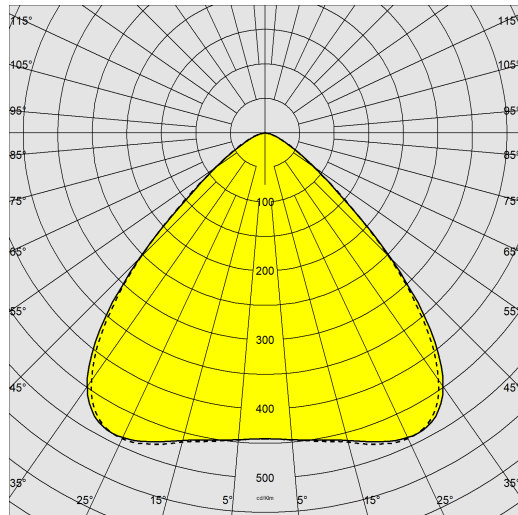

Lighting source	LED
CRI	80
Luminous flux (output) (lm)	16340 lm
Power absorption (total) (W)	77 W
CCT	4000 K
Low Flicker	luminaire with very low flicker: evenly distributed light for greater visual safety.
Colour consistency	SDCM3
LED flux maintenance	80000 hr, L 80, B 10

### MECHANICAL CHARACTERISTICS

Impact resistance rating (IK)	IK08
IP	66
Ambient temperature - min	-40 °C
Ambient temperature - max	60 °C

## 2885 - Saturno ø370 HE - high efficiency

Code: 330775-00

### MATERIALS AND COLOURS

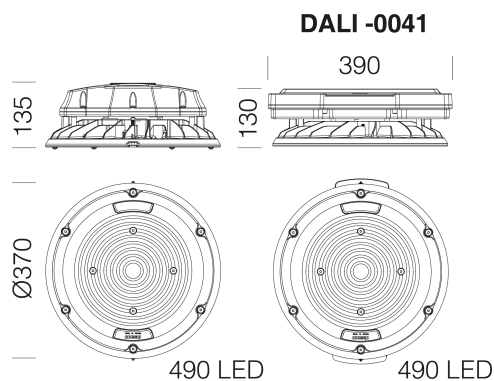

### DOWNLOAD

#### MOUNTS

[AssemblyInstructions gonsaturno.pdf](#)

[AssemblyInstructions saturno 370mm-hp 12-23.pdf](#)

[AssemblyInstructions saturno dismart 01-21.pdf](#)

[AssemblyInstructions saturno sensor 09-17.pdf](#)

[AssemblyInstructions Saturno DALI.pdf](#)

#### DESIGNS

[BIM 2885 Saturno HE 02-24](#)

[TechnicalDrawing 2885-he.dxf](#)



Housing	in die-cast aluminium with cooling fins integrated in the cover.
Diffuser	transparent polycarbonate, LED with protective lenses.
Heat sink	the heat sink is designed and made to allow the LEDs to operate at temperatures capable of ensuring excellent performance/output and long service life.
Coating	pre-treatment of metal surface, polyester powder coating to ensure resistance to corrosion and salt spray fogs, UV stabilised.
Special coating (UPON REQUEST)	Upon request: protective coating recommended for marine environments within 5 km (3 miles) of the sea.
Colour	Graphite
Equipment	<ul style="list-style-type: none"> <li>- waterproof connector for quick installation with no need to open the fixture</li> <li>- temperature controller with auto-reset</li> <li>- EN 61547 compliant surge protection.</li> <li>- anti-condensation valve</li> </ul> <p style="text-align: right;">- emergency version: acc. 1175 (997651-00) to be purchased separately.</p>

### STANDARDS AND COMPLIANCE

Photobiological safety class	RG0
Markings and tests	CE
Reference standards	EN60598-1. With degree of protection according to EN60529. The lighting fixture meets all IFS and BRC requirements, and the regulation of the HACCP Directive regarding lighting systems installed in food processing plants.
Energy Label	C

### GEAR

Upon request	<ul style="list-style-type: none"> <li>-Class II fixtures, protection up to 10KV.</li> <li>-Built-in presence/light sensor with ON-OFF function, dimmable (0-10V, 1-10V or DALI) or for ZHAGA socket.</li> <li>-Centralized lighting point control or via external presence/lighting sensors.</li> <li>-CLD D-D (DALI) wiring with subcode -0041.</li> <li>-Emergency wiring with centralized power supply CLD EC (subcode -0050).</li> <li>-AMBER LED 2200K with subcode -73.</li> </ul>
--------------	---

### WARRANTY

After sales warranty	5 yr
----------------------	------

## 2885 - Saturno ø370 HE - high efficiency

Code: 330775-00



540 Skirt - 370 mm



Presence and light sensors - DIMM DALI



Presence sensors - STAND-ALONE

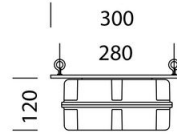

1175 EM Box - 997651-00