

# 1715 - Cripto COB medium - wide beam

Code: 413064-00

## GENERAL INFORMATION

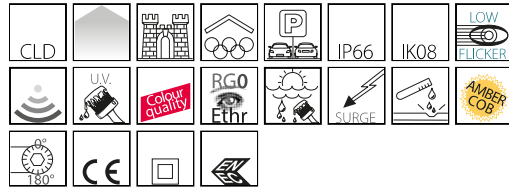

Article	1715 - Cripto COB medium - wide beam
Code	413064-00

## DIMENSIONS AND WEIGHT

Length (mm)	428 mm
Width (mm)	294 mm
Height (mm)	65 mm
Weight (Kg)	4 kg

## INSTALLATION

Surface exposed to wind (mm)	L 20500 mm <sup>2</sup> , F 85500 mm <sup>2</sup>
------------------------------	---

## ELECTRICAL CHARACTERISTICS AND CONTROLS

Voltage type	AC
Min Voltage (V)	220 V
Max Voltage (V)	240 V
Min Frequency (Hz)	50 Hz
Max Frequency (Hz)	60 Hz
Frequency (Hz)	50 Hz
Wiring name	CLD
Power factor	≥0.9
Surge protector (common) (EN 61547)	2 kV, 4 kV
Insulation class	Class II
Controllability	None



Disano presents a lighting fixture, designed as a possible retrofit for more classic models. The excellent performance of this luminaire in terms of energy saving and luminous efficiency is accompanied by a long lifespan, with IP66-rated materials for outdoor installations. The most advanced technology and design are used to reduce consumption and address the increasing need to replace obsolete equipment and save energy.



## 1715 - Cripto COB medium - wide beam

Code: 413064-00

### PHOTOMETRIC DATA

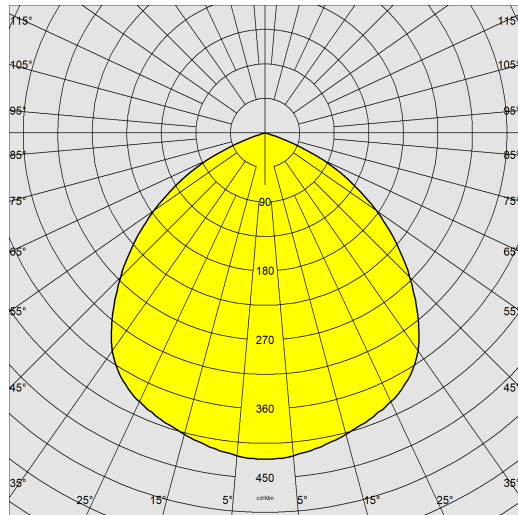

Lighting source	LED COB
CRI	80
Luminous flux (output) (lm)	11344 lm
Power absorption (total) (W)	70 W
CCT	4000 K
Luminous efficacy (lm/W)	162 lm/W
Low Flicker	luminaire with very low flicker: evenly distributed light for greater visual safety.
LED flux maintenance	50000 hr, L 80, B 20

### MECHANICAL CHARACTERISTICS

Impact resistance rating (IK)	IK08
IP	66
Ambient temperature - min	-20 °C
Ambient temperature - max	40 °C

# 1715 - Cripto COB medium - wide beam

Code: 413064-00

## MATERIALS AND COLOURS

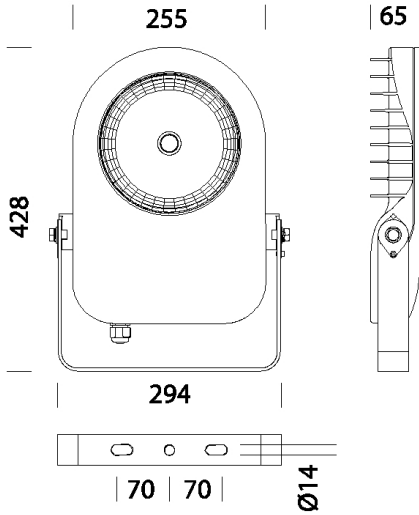

DOWNLOAD

### MOUNTS

[AssemblyInstructions cripto 12-23.pdf](#)

### DESIGNS

[TechnicalDrawing 1715.dxf](#)



Housing	in die-cast aluminium, with cooling fins.
Optics	in high-performance prismatic and polished aluminium.
Diffuser	tempered glass, 4 mm thick, resistant to thermal shock and impact (UNI EN 12150-1:2001).
Heat sink	the heat sink is designed and made to allow the LEDs to operate at temperatures capable of ensuring excellent performance/output and long service life.
Coating	pre-treatment of metal surface, polyester powder coating to ensure resistance to corrosion and salt spray fogs, UV stabilised.
Special coating (UPON REQUEST)	upon request: available with coating tested to withstand corrosion tests in aggressive artificial atmospheres (UNI EN ISO 9227) or marine environments (sea front).
Colour	Graphite
Equipment	<ul style="list-style-type: none"> <li>- with galvanised and painted bracket</li> <li>- EN 61547 compliant surge protection</li> <li>- silicone rubber gasket</li> <li>- external screws and bolts in stainless steel.</li> </ul>

## STANDARDS AND COMPLIANCE

Photobiological safety class	RG0 Ethr
Markings and tests	CE, ENEC
Reference standards	EN60598-1. With degree of protection according to EN60529.
Energy Label	D

## GEAR

Upon request	<ul style="list-style-type: none"> <li>- protection of up to 10kV</li> <li>- AMBER LED 2200K subcode -73</li> <li>- CLD-D (1-10V) wiring, subcode -12</li> <li>- CLD-D-D (DALI) wiring, subcode -0041</li> <li>- possibility of central light management or with external presence/light sensors.</li> </ul>
--------------	--

## WARRANTY

After sales warranty	5 yr
----------------------	------