

# 1727 - Cripto COB big - asymmetric

Code: 413150-00

## GENERAL INFORMATION

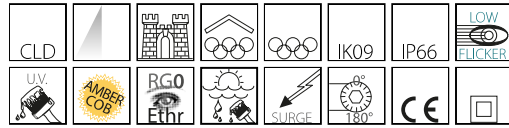

Article	1727 - Cripto COB big - asymmetric
Code	413150-00

## DIMENSIONS AND WEIGHT

Length (mm)	500 mm
Width (mm)	360 mm
Height (mm)	82 mm
Weight (Kg)	6 kg

## INSTALLATION

Surface exposed to wind (mm)	L 30800 mm <sup>2</sup> , F 126000 mm <sup>2</sup>
------------------------------	--

## ELECTRICAL CHARACTERISTICS AND CONTROLS

Voltage type	AC
Min Voltage (V)	220 V
Max Voltage (V)	240 V
Min Frequency (Hz)	50 Hz
Max Frequency (Hz)	60 Hz
Frequency (Hz)	50 Hz
Wiring name	CLD
Power factor	≥0.92
Surge protector (common) (EN 61547)	2 kV, 4 kV
Insulation class	Class II
Controllability	None



Disano presents a lighting fixture, designed as a possible retrofit for more classic models. The excellent performance of this luminaire in terms of energy saving and luminous efficiency is accompanied by a long lifespan, with IP66-rated materials for outdoor installations. The most advanced technology and design are used to reduce consumption and address the increasing need to replace obsolete equipment and save energy.



## 1727 - Cripto COB big - asymmetric

Code: 413150-00

### PHOTOMETRIC DATA

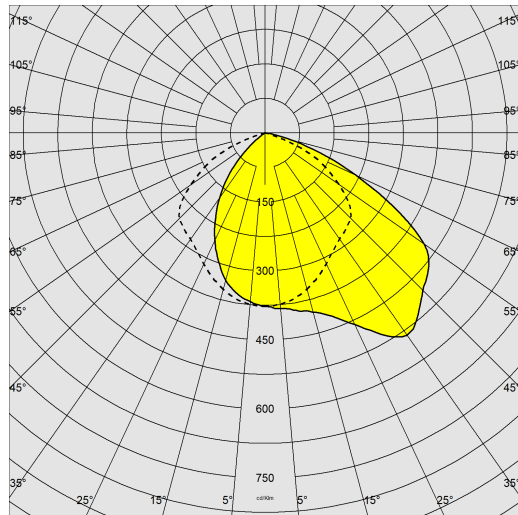

Distribution type	Asymmetric
Lighting source	LED COB
Luminous flux (output) (lm)	15528 lm
Power absorption (total) (W)	129 W
CCT	4000 K
Luminous efficacy (lm/W)	120 lm/W
Low Flicker	luminaire with very low flicker: evenly distributed light for greater visual safety.
LED flux maintenance	50000 hr, L 90, B 10

### MECHANICAL CHARACTERISTICS

Impact resistance rating (IK)	IK09
IP	66
Ambient temperature - min	-30 °C
Ambient temperature - max	40 °C



# 1727 - Cripto COB big - asymmetric

Code: 413150-00

## MATERIALS AND COLOURS

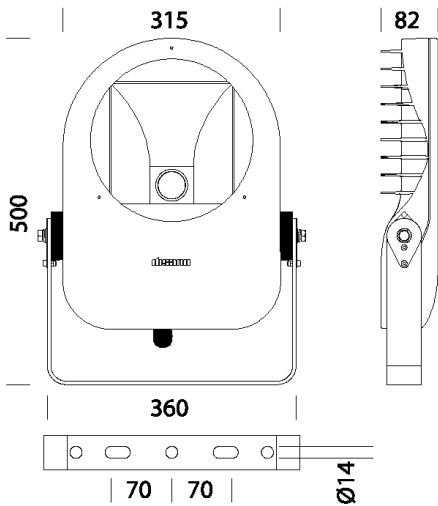

### DOWNLOAD

#### MOUNTS

[AssemblyInstructions cripto 12-23.pdf](#)

#### DESIGNS

[BIM 1727 09-25.zip](#)

[TechnicalDrawing 1727i.dxf](#)



Housing	in die-cast aluminium, with cooling fins.
Optics	in high gloss faceted aluminium.
Diffuser	tempered glass, 4 mm thick, resistant to thermal shock and impact (UNI EN 12150-1:2001).
Heat sink	the heat sink is designed and made to allow the LEDs to operate at temperatures capable of ensuring excellent performance/output and long service life.
Coating	the fully automated powder-coating cycle involves a polyester-based, salt-spray corrosion-resistant and UV-stabilised paint.
Special coating (UPON REQUEST)	Upon request: protective coating recommended for marine environments within 5 km (3 miles) of the sea.
Colour	Graphite
Equipment	<ul style="list-style-type: none"> <li>- with galvanised and painted bracket</li> <li>- EN 61547 compliant surge protection</li> <li>- silicone rubber gasket</li> <li>- external screws and bolts in stainless steel.</li> </ul>
	Luminous flux maintenance 70%: 100.000h (L70B50) o luminous flux maintenance 90%: 50.000h (L90B10).

## STANDARDS AND COMPLIANCE

Photobiological safety class	RG0 Ethr
Markings and tests	CE
Reference standards	EN60598-1. They have a degree of protection according to the EN60529 standard.
Energy Label	E

## GEAR

Sensors	
Upon request	<ul style="list-style-type: none"> <li>- protection of up to 10kV</li> <li>- AMBER LED 2200K subcode -73</li> <li>- CLD-D (1-10V) wiring, subcode -12</li> <li>- CLD-D-D (DALI) wiring, subcode -0041</li> <li>- possibility of central light management or with external presence/light sensors.</li> </ul>

## WARRANTY

After sales warranty	5 yr
----------------------	------

## 1727 - Cripto COB big - asymmetric

---

Code: 413150-00

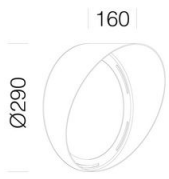

**625 Conveyor big**