

2169 - Radon HP - symmetric 3 MODULES

Code: 413492-0035

GENERAL INFORMATION

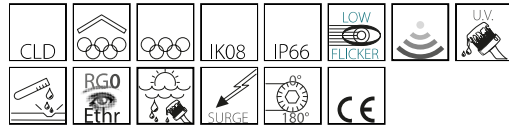

Article	2169 - Radon HP - symmetric 3 MODULES
Code	413492-0035

DIMENSIONS AND WEIGHT

Length (mm)	714 mm
Width (mm)	759 mm
Height (mm)	442 mm
Weight (Kg)	29.1 kg

INSTALLATION

Surface exposed to wind (mm)	L 125000 mm ² , F 466000 mm ²
------------------------------	---

ELECTRICAL CHARACTERISTICS AND CONTROLS

Voltage type	AC
Min Voltage (V)	220 V
Max Voltage (V)	240 V
Min Frequency (Hz)	50 Hz
Max Frequency (Hz)	60 Hz
Frequency (Hz)	50 Hz
Wiring name	CLD
Power factor	≥0.95
Surge protector (common) (EN 61547)	4 kV, 6 kV
Insulation class	Class I
Controllability	None

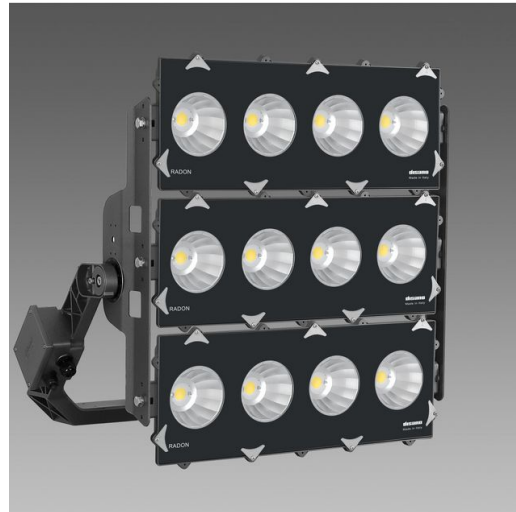

Radon in the floodlight version is very important in large surfaces, such as large public infrastructure or sports facilities. These fixtures must guarantee such features as robustness and reliability to ensure good lighting and long service life. These features, together with LED sources, are the main characteristics to create a lighting design that can guarantee good lighting and durability.

In the LED version, which can also be used for the relamping of old lighting installations, these floodlights offer outstanding performance in terms of energy savings, light quality and service life.

The fixtures of Disano's Radon LED series, made of aluminium with tempered glass, have all these qualities, starting with their extraordinary robustness, guaranteed by the superior quality of the materials and the anti-corrosion surface treatment.

Radon LED is available in asymmetric and symmetric versions. In addition to low flicker, Radon provides very important specifications for the safety and visual comfort of workers or athletes.

Radon LED is also a great investment for its long lifetime. These floodlights are ideal for installation in large areas or medium to large sports facilities. They allow high energy savings thanks to high luminous efficacy values.



2169 - Radon HP - symmetric 3 MODULES

Code: 413492-0035

PHOTOMETRIC DATA

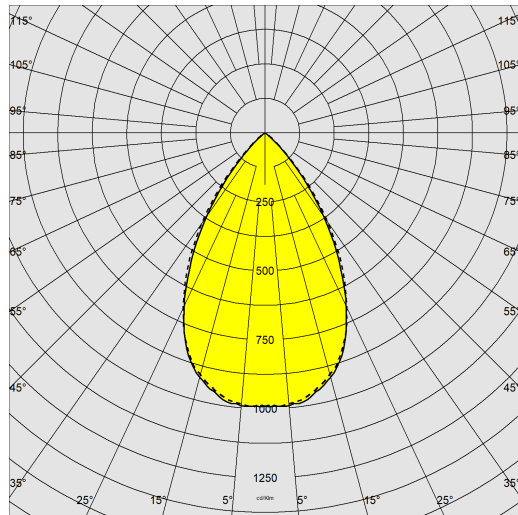

Distribution type	Symmetric wide beam
Lighting source	LED COB
CRI	80
Luminous flux (output) (lm)	148077 lm
Power absorption (total) (W)	885 W
CCT	5700 K
Luminous efficacy (lm/W)	167 lm/W
Low Flicker	luminaire with very low flicker: evenly distributed light for greater visual safety.
Beam angle	60 °
LED flux maintenance	90000 hr, L 80, B 10

MECHANICAL CHARACTERISTICS

Impact resistance rating (IK)	IK08
IP	66
Ambient temperature - min	-40 °C
Ambient temperature - max	45 °C



2169 - Radon HP - symmetric 3 MODULES

Code: 413492-0035

MATERIALS AND COLOURS

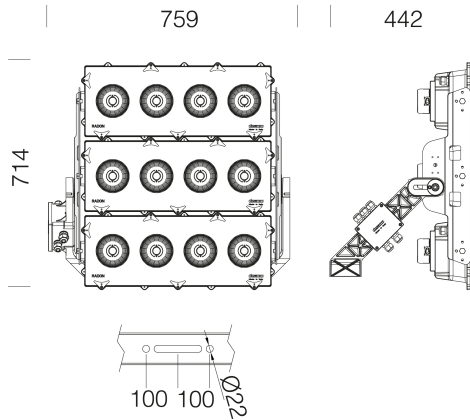

DOWNLOAD

MOUNTS

[AssemblyInstructions radon hp-he 06-23.pdf](#)

DESIGNS

[TechnicalDrawing 2169e.dxf](#)



Housing	aluminium.
Optics	in high-performance and anti-glare matt aluminium.
Diffuser	tempered glass, 4 mm thick, resistant to thermal shock and impact (UNI EN 12150-1:2001).
Heat sink	the heat sink is designed and made to allow the LEDs to operate at temperatures capable of ensuring excellent performance/output and long service life.
Coating	the fully automated powder-coating cycle involves a polyester-based, salt-spray corrosion-resistant and UV-stabilised paint., Anthracite = RAL 7021
Special coating (UPON REQUEST)	Upon request: protective coating recommended for marine environments within 5 km (3 miles) of the sea.
Colour	Anthracite
Equipment	<ul style="list-style-type: none"> - with galvanised and painted bracket - EN 61547 compliant surge protection. - anti-condensation valve - goniometric scale - silicone rubber gasket - external screws and bolts in stainless steel

STANDARDS AND COMPLIANCE

Photobiological safety class	RG0 Ethr
Markings and tests	CE
Reference standards	EN60598-1. They have a degree of protection according to the EN60529 standard.
Energy Label	D

WARRANTY

After sales warranty	5 yr
----------------------	------