

## 1988 - Mini Rodio - symmetric narrow beam

Code: 414930-00

### GENERAL INFORMATION



Article	1988 - Mini Rodio - symmetric narrow beam
Code	414930-00

### DIMENSIONS AND WEIGHT

Length (mm)	400 mm
Width (mm)	273 mm
Height (mm)	70 mm
Weight (Kg)	3.6 kg

### INSTALLATION

Surface exposed to wind (mm)	L 24200 mm <sup>2</sup> , F 80700 mm <sup>2</sup>
------------------------------	---

### ELECTRICAL CHARACTERISTICS AND CONTROLS

Voltage type	AC
Min Voltage (V)	220 V
Max Voltage (V)	240 V
Min Frequency (Hz)	50 Hz
Max Frequency (Hz)	60 Hz
Frequency (Hz)	50 Hz
Wiring name	CLD
Power factor	≥0.9
Surge protector (common) (EN 61547)	6 kV, 8 kV
Insulation class	Class I
Controllability	None



Within the range of floodlights, an excellent technological result has been achieved with the new Mini Rodio from the Rodio series. The small dimensions of this luminaire allow it to be inserted into any architecture or setting, for an aesthetic and high-tech lighting project. It is available in many versions with symmetric or asymmetric lenses, and also in a version with COB LEDs.

The excellent performance of this floodlight in terms of energy savings and luminous efficiency is accompanied by a long lifespan of 50/80,000 hours; furthermore, the use of materials with IP66 protection makes the Mini Rodio perfectly suitable for outdoor installations.

These spotlights are characterised by better light quality and a long lifespan, both guaranteed by the best possible materials and the most advanced LED sources.



## 1988 - Mini Rodio - symmetric narrow beam

Code: 414930-00

### PHOTOMETRIC DATA

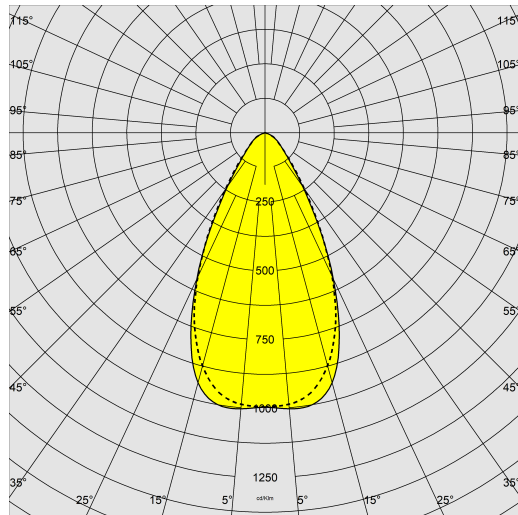

Distribution type	Symmetric narrow beam
Lighting source	LED
CRI	80
Luminous flux (output) (lm)	9242 lm
Power absorption (total) (W)	54 W
CCT	4000 K
Luminous efficacy (lm/W)	171 lm/W
Low Flicker	luminaire with very low flicker: evenly distributed light for greater visual safety.
Colour consistency	SDCM4
LED flux maintenance	100000 hr, L 90, B 10

### MECHANICAL CHARACTERISTICS

Impact resistance rating (IK)	IK08
IP	66
Ambient temperature - min	-20 °C
Ambient temperature - max	40 °C



# 1988 - Mini Rodio - symmetric narrow beam

Code: 414930-00

## MATERIALS AND COLOURS

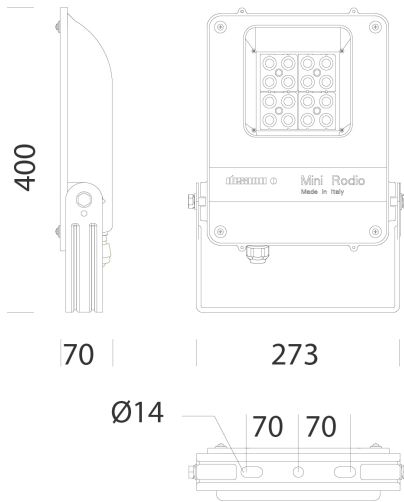

Housing	in die-cast aluminium with cooling fins integrated in the cover.
Optics	in high-performance PMMA resistant to high temperatures and UV rays.
Diffuser	tempered glass, 4 mm thick, resistant to thermal shock and impact (UNI EN 12150-1:2001).
Heat sink	the heat sink is designed and made to allow the LEDs to operate at temperatures capable of ensuring excellent performance/output and long service life.
Coating	the fully automated powder-coating cycle involves a polyester-based, salt-spray corrosion-resistant and UV-stabilised paint.
Special coating (UPON REQUEST)	Upon request: protective coating recommended for marine environments within 5 km (3 miles) of the sea.
Colour	Graphite
Equipment	<ul style="list-style-type: none"> <li>- with galvanised and painted bracket</li> <li>- cable for electrical connection</li> <li>- EN 61547 compliant surge protection</li> <li>- silicone rubber gasket</li> <li>- external screws and bolts in stainless steel.</li> </ul>

## DOWNLOAD

### MOUNTS

[AssemblyInstructions mini rodio 12-23.pdf](#)

### DESIGNS

[BIM 1988 - 07-25.zip](#)

[TechnicalDrawing 1988w.dxf](#)

[TechnicalDrawing3D disano 1988 minirodio.3ds](#)



## STANDARDS AND COMPLIANCE

Photobiological safety class	RG0 Ethr
Markings and tests	CE, ENEC
Reference standards	EN60598-1. They have a degree of protection according to the EN60529 standard.
Energy Label	C

## GEAR

Sensors	
Upon request	<ul style="list-style-type: none"> <li>- protection of up to 10kV.</li> <li>- amber LED (subcode -73 - 2200K)</li> <li>- CLD-D-D (DALI) wiring (subcode -0041)</li> <li>- possibility of central light management or with external presence/light sensors.</li> </ul>

## WARRANTY

After sales warranty	5 yr
----------------------	------

## 1988 - Mini Rodio - symmetric narrow beam

Code: 414930-00



**333 Connection for diam. 60 pole**



**334 Connection for diam. 76 pole**

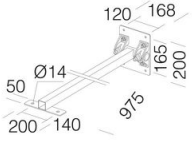

**42 Adjustable arm**