

## 1293 - Cilindro 4

Code: 420410-73

### GENERAL INFORMATION



Article	1293 - Cilindro 4
Code	420410-73

### DIMENSIONS AND WEIGHT

Length (mm)	280 mm
Width (mm)	185 mm
Height (mm)	350 mm
Weight (Kg)	5.5 kg

### ELECTRICAL CHARACTERISTICS AND CONTROLS

Voltage type	AC
Min Voltage (V)	220 V
Max Voltage (V)	240 V
Min Frequency (Hz)	50 Hz
Max Frequency (Hz)	60 Hz
Frequency (Hz)	50 Hz
Wiring name	CLD
Power factor	≥0.9
Insulation class	Class I
Controllability	None



Characterised by a careful attention to detail and a beautiful finish, Cilindro is a lighting fixture that also emits high quality light.

Indirect/direct lighting or only direct lighting used in a modular manner can enhance full and empty spaces, highlight external architectural details, and give dynamism to surfaces in refined interiors.

The Cilindro lamp can be surface-mounted or used as a pendant.



## 1293 - Cilindro 4

Code: 420410-73

### PHOTOMETRIC DATA

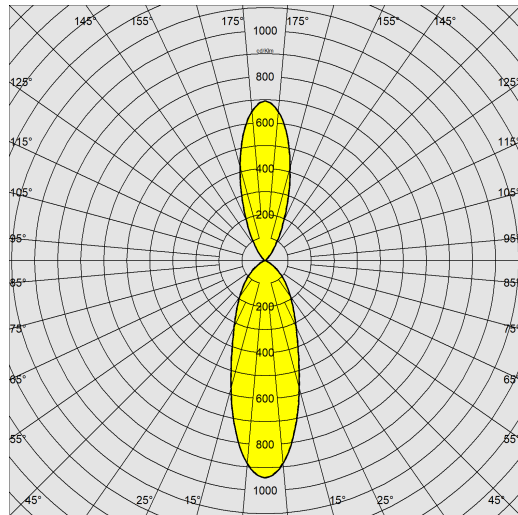

Lighting source	LED COB AMBER
CRI	amber
Luminous flux (output) (lm)	3470 lm
Power absorption (total) (W)	40 W
CCT	2200 K
Luminous efficacy (lm/W)	87 lm/W
LED flux maintenance	50000 hr, L 70, B 50

### MECHANICAL CHARACTERISTICS

Impact resistance rating (IK)	IK08
IP	65



## 1293 - Cilindro 4

Code: 420410-73

### MATERIALS AND COLOURS

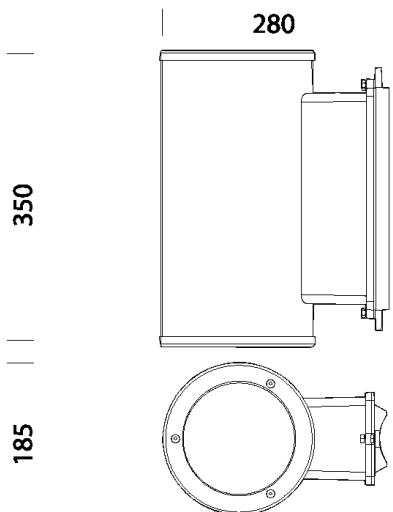

Housing	in die-cast aluminium.
Diffuser	tempered glass, 4 mm thick, resistant to thermal shock and impact (UNI EN 12150-1:2001).
Coating	the fully automated powder-coating cycle involves a polyester-based, salt-spray corrosion-resistant and UV-stabilised paint.
Colour	Grey
Equipment	built-in temperature controller with auto-reset. Surge protection in compliance with EN61547.

### STANDARDS AND COMPLIANCE

Photobiological safety class	RG0 Ethr
Markings and tests	CE
Reference standards	EN60598-1. They have a degree of protection according to the EN60529 standard.
Energy Label	E

### DOWNLOAD

#### MOUNTS

[AssemblyInstructions 1293 10-22.pdf](#)

#### DESIGNS

[TechnicalDrawing 1293g.dxf](#)



### WARRANTY

After sales warranty 3 yr

## 1293 - Cilindro 4

Code: 420410-73

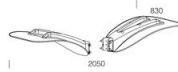

**388 Pegaso double slab**

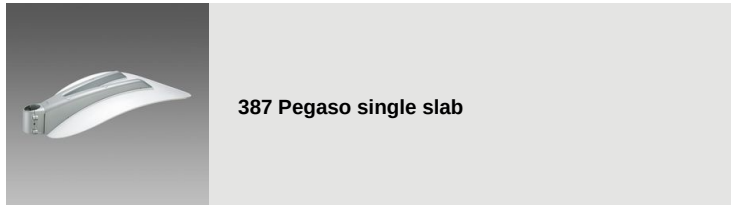

**401 cylindrical wall mount**