

1583 - Vista LED COB

Code: 422212-00

GENERAL INFORMATION

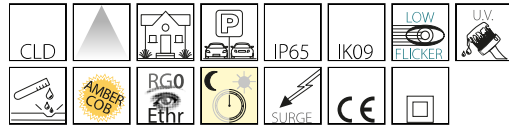

Article	1583 - Vista LED COB
Code	422212-00

DIMENSIONS AND WEIGHT

Length (mm)	585 mm
Width (mm)	585 mm
Height (mm)	550 mm
Weight (Kg)	10.3 kg

INSTALLATION

Diameter (Ø) of pole connector (mm)	60-60 mm
Surface exposed to wind (mm)	L 168000 mm ² , F 168000 mm ²

ELECTRICAL CHARACTERISTICS AND CONTROLS

Voltage type	AC
Min Voltage (V)	220 V
Max Voltage (V)	240 V
Min Frequency (Hz)	50 Hz
Max Frequency (Hz)	60 Hz
Frequency (Hz)	50 Hz
Wiring name	CLD
Power factor	≥0.9
Rated Current	1400 mA
Surge protector (common) (EN 61547)	10 kV, 10 kV
Insulation class	Class II
Controllability	None



Vista is one of Disano's most popular street lamps. Designed for the lighting of parks, Vista can blend seamlessly into gardens and green areas or into well-tended and special urban settings.

A good lighting infrastructure enhances the feeling of safety and embellishes a public square or a neighbourhood, allowing spaces to come alive in the evenings.

Vista LED is the version with latest generation LED modules.



1583 - Vista LED COB

Code: 422212-00

PHOTOMETRIC DATA

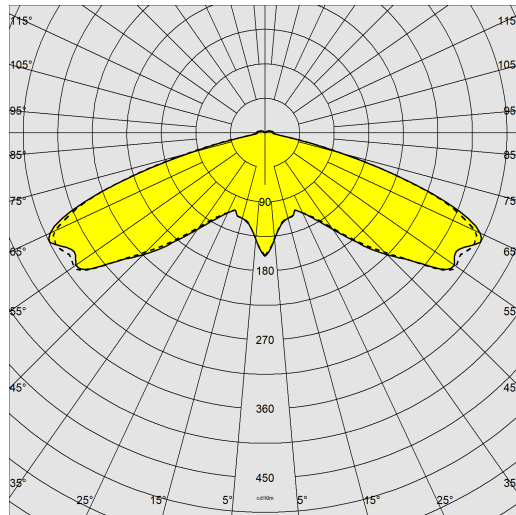

Lighting source	LED COB
CRI	≥80
Luminous flux (output) (lm)	3700 lm
Power absorption (total) (W)	53 W
CCT	4000 K
Luminous efficacy (lm/W)	70 lm/W
Low Flicker	luminaire with very low flicker: evenly distributed light for greater visual safety.
LED flux maintenance	50000 hr, L 80, B 20

MECHANICAL CHARACTERISTICS

Impact resistance rating (IK)	IK09
IP	65
Ambient temperature - min	-20 °C
Ambient temperature - max	40 °C

1583 - Vista LED COB

Code: 422212-00

MATERIALS AND COLOURS

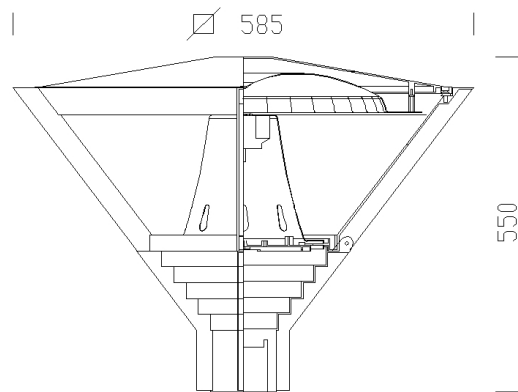

Housing	in die-cast aluminium.
Diffuser	in anti-glare polycarbonate, shatterproof and V2 self-extinguishing, UV stabilised, externally smooth and dustproof.
Heat sink	built-in.
Pole connection	suited for poles with a diameter of 60 mm.
Coating	the fully automated powder-coating cycle involves a polyester-based, salt-spray corrosion-resistant and UV-stabilised paint.
Colour	Graphite
Equipment	<ul style="list-style-type: none"> - selector switch. - waterproof connector for quick installation with no need to open the fixture. - anti-condensation valve. - temperature controller with auto-reset. - EN 61547 compliant surge protection.

STANDARDS AND COMPLIANCE

Photobiological safety class	RG0 Ethr
Markings and tests	CE
Reference standards	EN60598-1. They have a degree of protection according to the EN60529 standard.
Energy Label	E

DOWNLOAD

MOUNTS

[AssemblyInstructions vista 03-23.pdf](#)

DESIGNS

[BIM 1583 Vista LED COB - 20200604](#)

[TechnicalDrawing 1583 vista led.dxf](#)



WARRANTY

After sales warranty	5 yr
----------------------	------