

1212 - Box - vertical screen

Code: 431603-00

GENERAL INFORMATION



| | |
|---------|------------------------------|
| Article | 1212 - Box - vertical screen |
| Code | 431603-00 |

DIMENSIONS AND WEIGHT

| | |
|-------------|--------|
| Length (mm) | 114 mm |
| Width (mm) | 96 mm |
| Height (mm) | 223 mm |
| Weight (Kg) | 0.5 kg |

INSTALLATION

| | |
|-----------------------------------|--------|
| Recessed dimensions - Length (mm) | 215 mm |
| Recessed dimensions - Width (mm) | 110 mm |

ELECTRICAL CHARACTERISTICS AND CONTROLS

| | |
|--------------------|---------|
| Voltage type | AC |
| Min Voltage (V) | 220 V |
| Max Voltage (V) | 240 V |
| Min Frequency (Hz) | 50 Hz |
| Max Frequency (Hz) | 60 Hz |
| Frequency (Hz) | 50 Hz |
| Wiring name | CLD |
| Power factor | ≥0.9 |
| Insulation class | Class I |
| Controllability | None |



1212 Box - vertical screen



1212 - Box - vertical screen

Code: 431603-00

PHOTOMETRIC DATA



| | |
|------------------------------|----------------------|
| Lighting source | LED |
| CRI | 80 |
| Luminous flux (output) (lm) | 280 lm |
| Power absorption (total) (W) | 3 W |
| CCT | 4000 K |
| LED flux maintenance | 50000 hr, L 70, B 50 |

MECHANICAL CHARACTERISTICS

| | |
|-------------------------------|------|
| Impact resistance rating (IK) | IK08 |
| IP | 54 |

1212 - Box - vertical screen

Code: 431603-00

MATERIALS AND COLOURS

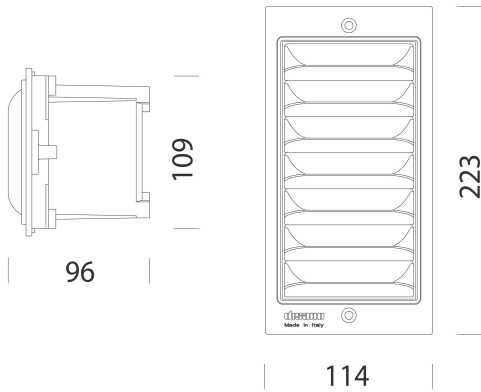

| | |
|-----------|--|
| Housing | in fibreglass nylon, shatterproof, UV stabilised, frame in die-cast aluminium. |
| Diffuser | tempered glass, resistant to thermal shock and impact (UNI EN 12150-1:2001). |
| Coating | the fully automated powder-coating cycle involves a polyester-based, salt-spray corrosion-resistant and UV-stabilised paint. |
| Colour | Graphite |
| Equipment | silicone and EPDM rubber sealing gasket. |

STANDARDS AND COMPLIANCE

| | |
|------------------------------|--|
| Photobiological safety class | RG0 |
| Markings and tests | CE |
| Reference standards | EN60598-1. They have a degree of protection according to the EN60529 standard. |
| Energy Label | F |

DOWNLOAD

MOUNTS

[AssemblyInstructions box 04-23.pdf](#)

DESIGNS

[TechnicalDrawing 1212.dxf](#)



WARRANTY

| | |
|----------------------|------|
| After sales warranty | 3 yr |
|----------------------|------|