

1537 - Koala ES

Code: 431803-00

GENERAL INFORMATION

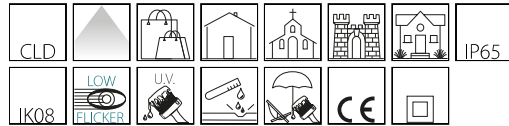

Article	1537 - Koala ES
Code	431803-00

DIMENSIONS AND WEIGHT

Height (mm)	196 mm
Diameter (Ø) (mm)	127 mm
Weight (Kg)	0.7 kg

ELECTRICAL CHARACTERISTICS AND CONTROLS

Voltage type	AC
Min Voltage (V)	220 V
Max Voltage (V)	240 V
Min Frequency (Hz)	50 Hz
Max Frequency (Hz)	60 Hz
Frequency (Hz)	50 Hz
Wiring name	CLD-D
Power factor	≥0.9
Insulation class	Class I
Controllability	None



Restyling of the classic garden spotlight with a slender shape. The LED in outdoor lighting is now a guarantee for quality with the advantage of significant energy savings. In the LED version, Koala ensures excellent colour rendering that guarantee perfect, homogeneous light, especially for the lighting of monuments or building façades. Carefully designed for maximum efficiency and durability. Available with multiple accessories and in three colours: silver, graphite, corten.



1537 - Koala ES

Code: 431803-00

PHOTOMETRIC DATA

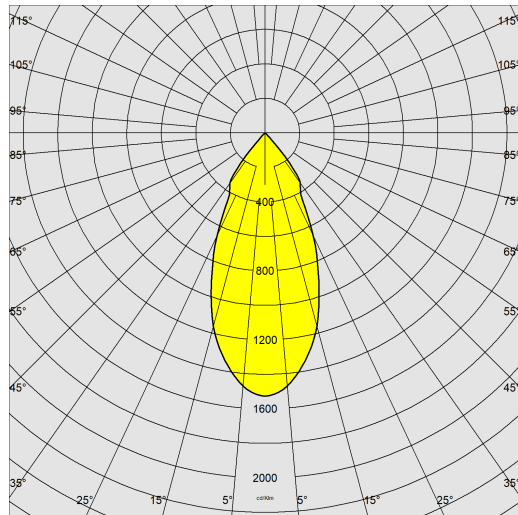

Lighting source	LED SMD
CRI	80
Luminous flux (output) (lm)	429 lm
Power absorption (total) (W)	7 W
CCT	3000 K
Luminous efficacy (lm/W)	61 lm/W
Beam angle	38 °
LED flux maintenance	25000 hr, L 70, B 50

MECHANICAL CHARACTERISTICS

Impact resistance rating (IK)	IK08
IP	65



1537 - Koala ES

Code: 431803-00

MATERIALS AND COLOURS

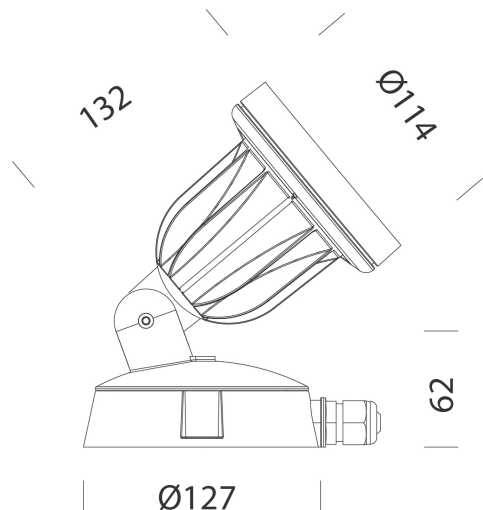

DOWNLOAD

MOUNTS

[AssemblyInstructions KOALA 09-22.pdf](#)

DESIGNS

[TechnicalDrawing 1537di.dxf](#)



Housing	in die-cast aluminium with cooling fins integrated in the cover.
Diffuser	extra-clear, tempered glass, 4 mm thick, resistant to thermal shock and impact (UNI-EN 12150-1:2001).
Coating	pre-treatment of metal surface, polyester powder coating, resistance to corrosion, UV stabilised. Standard with coating for marine environments in compliance with UNI EN ISO 9227.
Special coating (UPON REQUEST)	Upon request: protective coating recommended for marine environments within 5 km (3 miles) of the sea.
Colour	Graphite
Equipment	cable gland diam. 3/8.

STANDARDS AND COMPLIANCE

Photobiological safety class	RG0 Ethr
Markings and tests	CE
Reference standards	EN60598-1. With degree of protection according to EN60529.

WARRANTY

After sales warranty	3 yr
----------------------	------

1537 - Koala ES

Code: 431803-00



118 Terminal

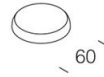

115 Pole cap

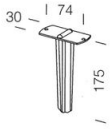

119 Spike



116 Angle support

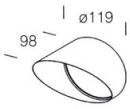

114 Conveyor

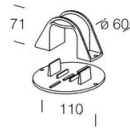

120 Pole support