

1564 - Elfo Amber - FS

Code: 432838-73

GENERAL INFORMATION

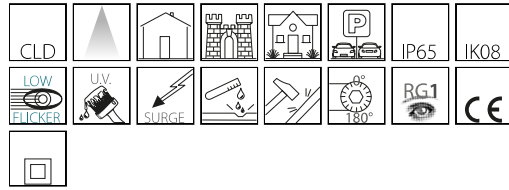

Article	1564 - Elfo Amber - FS
Code	432838-73

DIMENSIONS AND WEIGHT

Length (mm)	220 mm
Width (mm)	220 mm
Height (mm)	310 mm
Weight (Kg)	2.6 kg

ELECTRICAL CHARACTERISTICS AND CONTROLS

Voltage type	AC
Min Voltage (V)	220 V
Max Voltage (V)	240 V
Min Frequency (Hz)	50 Hz
Max Frequency (Hz)	60 Hz
Frequency (Hz)	50 Hz
Wiring name	CLD
Power factor	≥ 0.9
Insulation class	Class II
Controllability	None

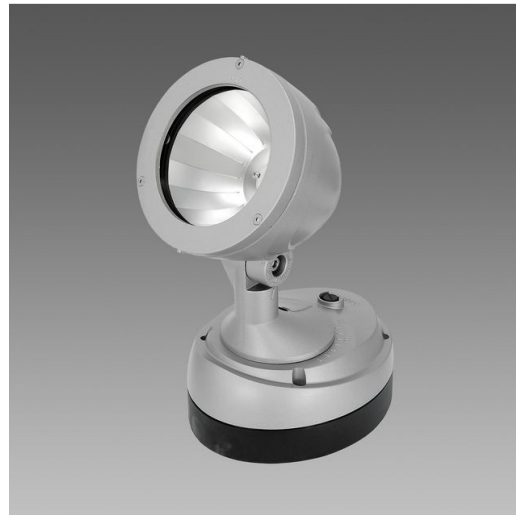

A complete product that meets needs and wishes of lighting designers.



1564 - Elfo Amber - FS

Code: 432838-73

PHOTOMETRIC DATA

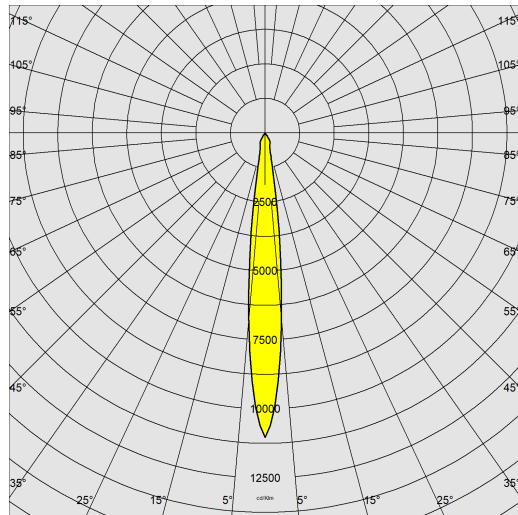

Lighting source	LED AMBER
CRI	Amber
Luminous flux (output) (lm)	5740 lm
Power absorption (total) (W)	57 W
CCT	2200 K
Luminous efficacy (lm/W)	101 lm/W
Beam angle	15 °
LED flux maintenance	50000 hr, L 80, B 20

MECHANICAL CHARACTERISTICS

Impact resistance rating (IK)	IK08
IP	65



1564 - Elfo Amber - FS

Code: 432838-73

MATERIALS AND COLOURS

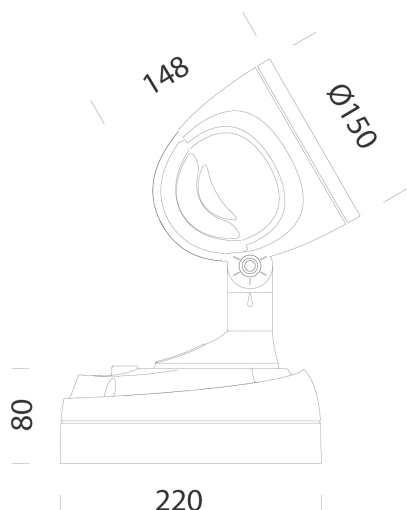

DOWNLOAD

MOUNTS

[AssemblyInstructions Elfo 03-23.pdf](#)

DESIGNS

[TechnicalDrawing elfoled.dxf](#)



Housing	in die-cast aluminium with cooling fins integrated in the cover.
Optics	in high-performance silver-coated aluminium.
Diffuser	tempered glass, 4 mm thick, resistant to thermal shock and impact (UNI EN 12150-1:2001).
Coating	the fully automated powder-coating cycle involves a polyester-based, salt-spray corrosion-resistant and UV-stabilised paint.
Special coating (UPON REQUEST)	Upon request: protective coating recommended for marine environments within 5 km (3 miles) of the sea.
Colour	Grey
Equipment	silicone and EPDM rubber sealing gasket. Rubber cable gland Ø 1/2 gas inch.

STANDARDS AND COMPLIANCE

Photobiological safety class	RG0 Ethr
Markings and tests	CE
Reference standards	EN60598-1. They have a degree of protection according to the EN60529 standard.
Energy Label	D

WARRANTY

After sales warranty	3 yr
----------------------	------

1564 - Elfo Amber - FS

Code: 432838-73

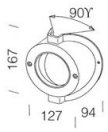

116 Angle support

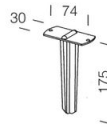

119 Spike

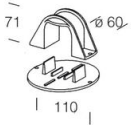

120 Pole support

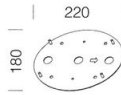

188 Board