

1883 - Minifloor

Code: 530785-00

GENERAL INFORMATION

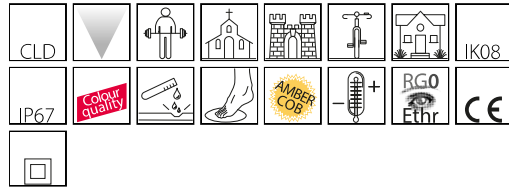

Article	1883 - Minifloor
Code	530785-00

DIMENSIONS AND WEIGHT

Height (mm)	329 mm
Diameter (Ø) (mm)	300 mm
Weight (Kg)	5 kg

ELECTRICAL CHARACTERISTICS AND CONTROLS

Voltage type	AC
Min Voltage (V)	220 V
Max Voltage (V)	240 V
Min Frequency (Hz)	50 Hz
Max Frequency (Hz)	60 Hz
Frequency (Hz)	50 Hz
Wiring name	CLD
Power factor	≥0.95
Insulation class	Class II
Controllability	None



Gamma Minifloor, one further step towards a more technical lighting of surfaces.
Accent lighting emphasises details and adds a third dimension to objects.
Both classic and modern styles produce the same effect.



1883 - Minifloor

Code: 530785-00

PHOTOMETRIC DATA

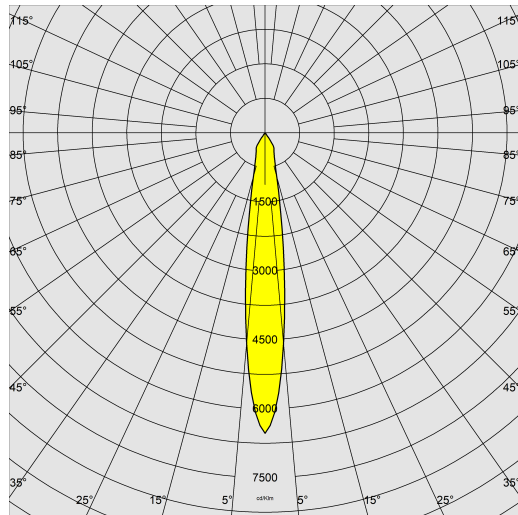

Lighting source	LED
CRI	80
Luminous flux (output) (lm)	1447 lm
Power absorption (total) (W)	12 W
CCT	3000 K
Luminous efficacy (lm/W)	121 lm/W
Beam angle	15 °
LED flux maintenance	50000 hr, L 90, B 10

MECHANICAL CHARACTERISTICS

Impact resistance rating (IK)	IK08
Max load	2000 kg
Walkover	True
Driveover	True
IP	67



1883 - Minifloor

Code: 530785-00

MATERIALS AND COLOURS

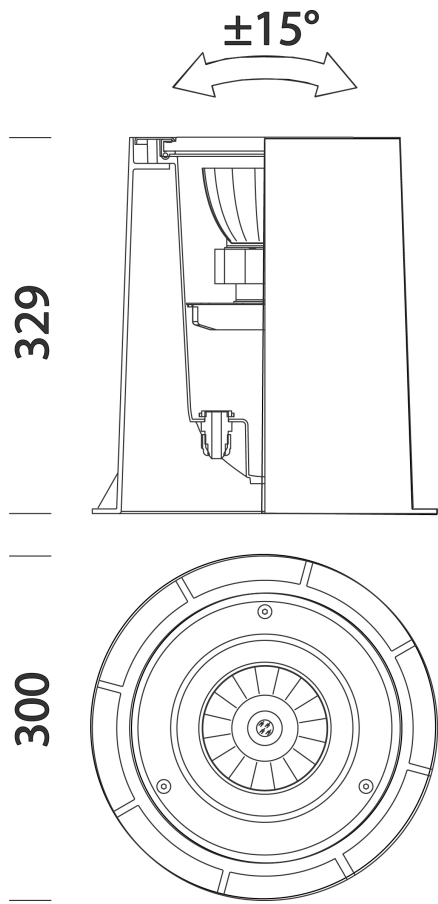

Housing	in die-cast aluminium with outer shell in fibreglass nylon, frame in AISI 316L stainless steel.
Optics	in high-performance metallised polycarbonate.
Diffuser	tempered glass, 8 mm thick, resistant to thermal shock and impact and loads of up to 2000 kg (UNI EN 12150-1:2001).
Colour	Stainless steel
Equipment	<ul style="list-style-type: none"> - standard with flush-mounted boxes. - silicone rubber sealing gasket. - in fibreglass nylon cable gland diam. 1/2 inch gas. - anti-seize bolts
driveway lamp. Keep clear.	

STANDARDS AND COMPLIANCE

Photobiological safety class	RG0 Ethr
Markings and tests	CE
Reference standards	EN60598-1. They have a degree of protection according to the EN60529 standard.
Laboratory Tests	the luminaire passed the static load resistance test (EN 60598-2-13) with an applied weight of 40KN equal to 2000 kg.
Energy Label	E

GEAR

Sensors	
Upon request	version with IP68 protection and hermetic gel system at the bottom of the luminaire (not suitable for immersion installation).

DOWNLOAD

MOUNTS

[AssemblyInstructions 1883 extra.pdf](#)

[AssemblyInstructions 1883 04-23.pdf](#)

[AssemblyInstructions 369 399 mount.pdf](#)

DESIGNS

[TechnicalDrawing 1883a.dxf](#)



WARRANTY

After sales warranty	3 yr
----------------------	------

1883 - Minifloor

Code: 530785-00

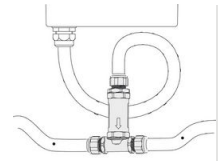

399 Connector for continuous light line

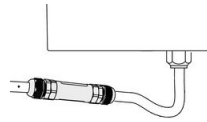

369 Connector