

## 365 - Connection for two-lamp pole

Code: 998022-00

### GENERAL INFORMATION

Article	365 - Connection for two-lamp pole
Code	998022-00

### DIMENSIONS AND WEIGHT

Height (mm)	155 mm
Diameter (Ø) (mm)	100 mm
Weight (Kg)	1.276 kg

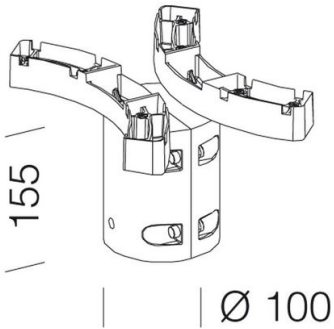

365 Attacco palo bilampada



## 365 - Connection for two-lamp pole

---

Code: 998022-00



## 365 - Connection for two-lamp pole

Code: 998022-00

### MATERIALS AND COLOURS

Housing	in die-cast aluminium. For installation on 60-diameter pole in the two-lamp version.
Pole connection	//
Colour	Graphite

### STANDARDS AND COMPLIANCE

Markings and tests	CE
--------------------	----

### WARRANTY

After sales warranty	0 yr
----------------------	------

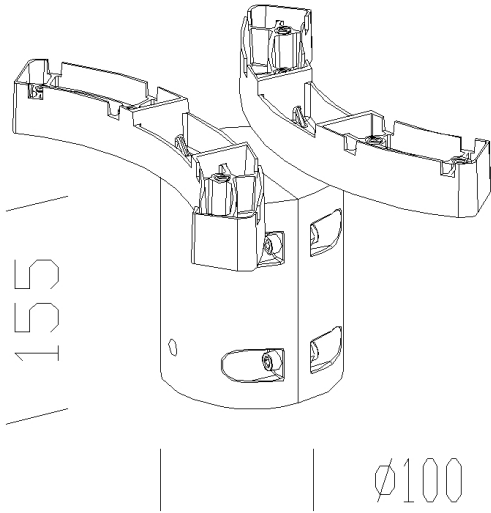

[DOWNLOAD](#)

### DESIGNS

[TechnicalDrawing 365.dxf](#)



## 365 - Connection for two-lamp pole

---

Code: 998022-00



**1777 Musa LED cycle-pedestrian**



**1779 Musa LED**